



# Completely Clear 1200

Filter and Fountain Kit

**All-in-One Submersible Filter System  
supports ponds up to 1,200 gallons**



- Includes filter pads for additional mechanical filtration
- Compact base unit  
17" L x 12" W x 6" H
- Overall height: 22"
- 25-foot power cord for flexible placement
- Durable, easy to install, and low maintenance design

# Completely Clear 1200

## All-in-one submersible filter system.

Supports ponds up to 1,200 gallons without fish, or up to 600 gallons with moderate fish load.

- **525 GPH magnetic drive pump**  
Energy efficient and runs for pennies a day
- **9-Watt UV Clarifier**  
sterilizes suspended algae to eliminate green water
- **Zeolite Crystals**  
reduce harmful ammonia, creating a cleaner and healthier pond for koi and goldfish
- **Bio Balls**  
unique shape increases surface area to cultivate beneficial bacteria
- **Built-in Diverter Valve**  
choose full flow to fountain head or divert water to pondside spitter

## Completely Clear 1200 Pump Main Body

The Main Body of your pump has four filter components.

- **Zeolite Crystals**  
These are the white mineral pieces found in the mesh bag. Zeolite crystals are used to remove ammonia from pond water. This is especially important for pond health when fish are present.
- **Bio Balls**  
The plastic spheres are placed on the bottom of the pump housing. Bio Balls increase surface area for beneficial bacteria to grow, keeping your pond healthy.
- **Small Filter pad**
- **Large Filter pad**

The following page shows the proper placement of each filtering component.

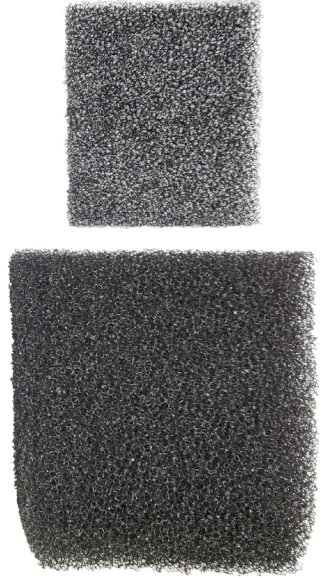

**Zeolite Crystals**

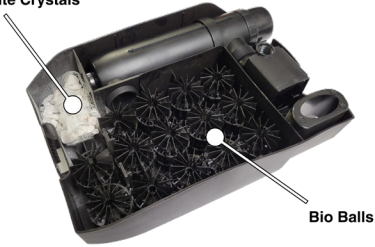

**Bio Balls**

**Small Filter Pad**



**Large Filter Pad**

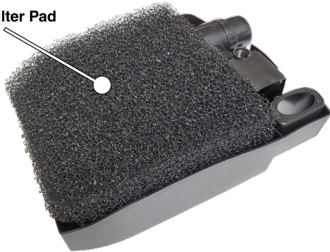

**Outer Cover**



# Completely Clear 1200 Fountain Spout

We recommend assembling the Fountain Spout separately, then attaching the completed spout to the main body of your Completely Clear Filter and Fountain.

- When assembling, do not over tighten threaded components.
- Teflon tape or pipe joint compound is **NOT** recommended for use when assembling the spout.
- This filter and fountain pump comes with 2 fountain heads.

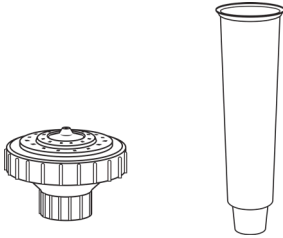

Only one may be used at a time

The following illustration shows the proper placement of each piping component.

This valve is used to have the pump push water to a spillway or other water spout. The dual valve allows you to adjust water flow.

1. Closing this valve diverts all water to the horizontal nozzle.
2. Closing this valve diverts all water to the vertical fountain spout.

Once the spout has been completely assembled, you can attach it to the filter and fountain pump.

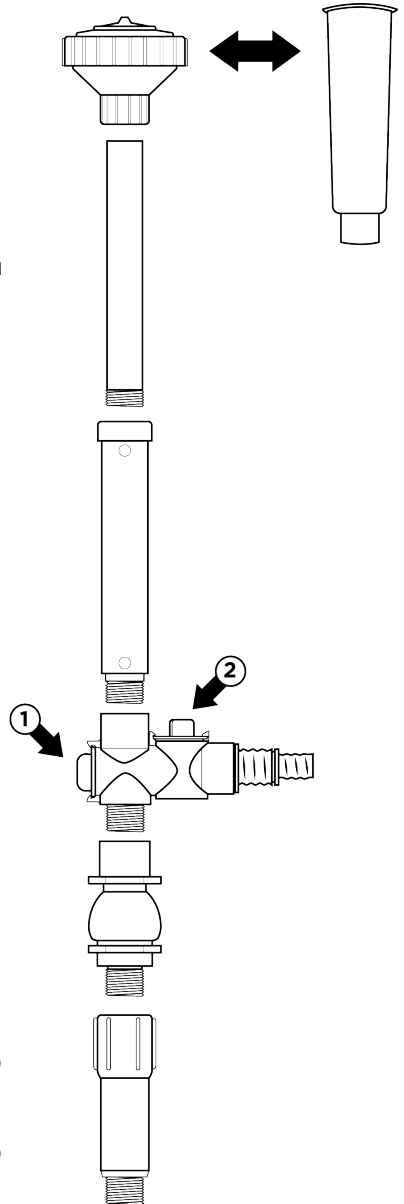



## Completely Clear 1200 UV

The Completely Clear 1200 comes with an integrated 9 watt UV Clarifier.

- The UV Clarifier breaks down organic material that is then removed by the filter, helping keep your water clear and clean. UV Sterilizers emit germicidal ultraviolet light that's comparable to sunlight, to help eliminate algae and bacteria, helping purify green water caused by free-floating algae.
- The effective life of the UV-C lamp is approx. 70000 hours.
- Anjon Manufacturing recommends UV bulb replacement at the beginning of each season will keep your UV Clarifier working at peak efficiency, and avoid issues with water clarity.
- The replacement bulb for your UV clarifier is:  
9-Watt UV Replacement Bulb  
part number: HOP09WATTUV



# Completely Clear 1200 Use

The Completely Clear 1200 is a biological pond filter. This means that the biological action will optimize after a few weeks of use. During the growing season, it is advisable to let the filter function continuously.

When the filter is not run for a periods of time 5 hours or longer, the beneficial bacteria that helps with water clarity and health will be greatly reduced.

If your Completely Clear fountain has not been running for more than 3 days, we recommend **Anjon Manufacturing Beneficial Bacteria** product to speed up establishment of the biological process.



## Completely Clear 1200 General and Seasonal Maintenance

- To avoid risk of shock, **ALWAYS** disconnect the electrical supply before performing any maintenance or servicing.
- During the winter season, when temperatures fall below 32°F, the filter should be turned off and removed from your pond. Exposing the filter to below freezing temperatures can cause damage to plastic components that is not covered by warranty.
- Zeolite Crystals will last the lifetime of your Completely Clear 1200. They can become saturated with ammonia, especially in ponds with fish. To regenerate your zeolite crystals, you can soak them in a concentrated salt water solution (6 tablespoons of salt dissolved in 1 gallon of water) for 24 hours to replace absorbed ammonia or hard minerals (calcium/magnesium) with sodium ions. Allow to dry before reinstalling your Completely Clear 1200.
- Use only water to clean the Bio Balls and large and small filter pads. Do NOT use detergents or cleaning agents on these items.
- To maximize the life of your Completely Clear 1200, Anjon Manufacturing recommends that you clean all parts and keep them in a dry frost free place.

# LIMITED WARRANTY

Products manufactured by ANJON MANUFACTURING are warranted to the original user only to be free of defects in material and workmanship for a period of 24 months from the date of purchase, but not more than 30 months from the date of manufacture. ANJON MANUFACTURING liability under this warranty shall be limited to repairing or replacing, at ANJON MANUFACTURING's discretion, without charge, F.O.B. ANJON MANUFACTURING will not be liable for any cost of removal, installation, transportation, or any other charges which may arise in connection with a warranty claim.

To obtain service under this warranty, the defective product must be returned to the distributor or dealer of ANJON MANUFACTURING's products from which it was purchased together with proof of purchase and installation date, failure date, and supporting installation data. Unless otherwise provided, the distributor or dealer will contact ANJON MANUFACTURING or an authorized service station for instructions. Any defective product to be returned to ANJON MANUFACTURING or a service station must be sent freight prepaid: documentation supporting the warranty claim and/or a Return Merchandise Authorization (RMA) must be included if so instructed. In the absence of suitable proof of purchase date, the effective date of this warranty will be based upon the date of manufacture.

Any replacement product may be either new or like-new, provided that it has functionality at least equal to that of the product being replaced. No requests for service under this warranty will be accepted if received more than 30 days after the term of the warranty. Correction of defects, in the manner and for the duration of the warranty described in this warranty, shall constitute complete fulfillment of all liabilities and responsibilities of ANJON MANUFACTURING to the user with respect to the product, and shall constitute full satisfaction of all claims, whether based on contract, negligence, and strict liability or otherwise. Except for the obligations specifically set forth in this warranty, in no event shall ANJON MANUFACTURING be liable for direct, indirect, special, incidental, or consequential damages, whether based on contract, tort, or any other legal theory and whether advised of the possibility of such damages.

ANJON MANUFACTURING reserves the right to change or improve its products or any portions thereof without being obligated to provide such a change or improvement for units sold and/or shipped prior to such a change or improvement.

THERE ARE NO EXPRESS OR IMPLIED WARRANTIES, INCLUDING MERCHANTABILITY OR FITNESS FOR A PARTICULAR PURPOSE, WHICH EXTEND BEYOND THOSE WARRANTIES DESCRIBED OR REFERRED TO ABOVE EXCEPT AS EXPRESSLY HEREIN PROVIDED THE GOODS ARE SOLD "AS IS", THE ENTIRE RISK AS TO QUALITY AND FITNESS FOR A PARTICULAR PURPOSE, AND PERFORMANCE OF THE GOODS IS WITH THE BUYER, AND SHOULD THE GOODS PROVE DEFECTIVE FOLLOWING THEIR PURCHASE, THE BUYER AND NOT THE MANUFACTURER, DISTRIBUTOR, OR RETAILER ASSUMES THE ENTIRE RISK OF ALL NECESSARY SERVICING AND REPAIR.

Some jurisdictions do not allow the exclusions or limitation of incidental or consequential damages and some jurisdictions do not allow limitations on how long implied warranties may last or require you to pay certain expenses as set forth above. Therefore, the above limitations or exclusions may not apply to you. This warranty gives you specific legal rights and you may also have other rights which vary from jurisdictions to jurisdiction.

Requests for review of a potential warranty claim can be submitted to [returns@anjonmfg.com](mailto:returns@anjonmfg.com)

You can also submit your request online at:  
<https://anjonmfg.com/warranty/>

# Completely Clear 1200 Pack List

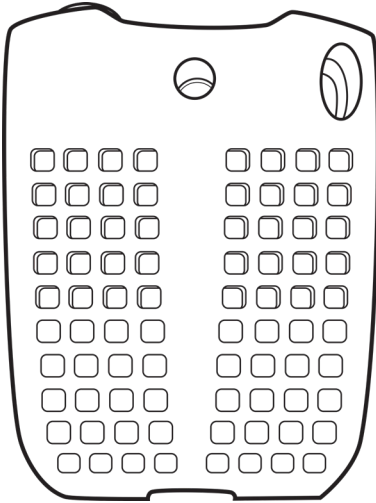

1 - Completely Clear Main Unit

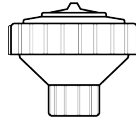

1 - shower fountain nozzle



1 - bell fountain nozzle

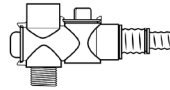

1 - diverter valve

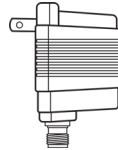

1 - 12 volt transformer



1 - 6" extension pipe

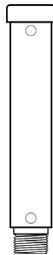

1 - 5.75" extension pipe



1 - 3" extension pipe



1 - ball joint



150 Anjon Way  
O'Fallon, Missouri, 63366 USA  
1-800-553-5605  
anjonmfg.com  
sales@anjonponds.com

Copyright ©2026