



# Owners Manual

## Aerator & Circulators



### Contents

Important Safety Instructions. . . . .	pg2
General Owner's Instructions. . . . .	pg2
Unit Specs. . . . .	pg3
2400AF, 3400AF/HAF, 4400AF/HAF Parts. . . . .	pg3
2400AF, 3400AF/HAF, 4400AF/HAF Assembly. . . . .	pg4
8400AF, 2.3AF, 3.1AF, 3.3AF, 5.1AF, 5.3AF Parts. . . . .	pg6
8400AF, 2.3AF, 3.1AF, 3.3AF, 5.1AF, 5.3AF Assembly. . . . .	pg6
Mesh Screen Attachment. . . . .	pg9
Installation Instructions. . . . .	pg9
Circulator Parts (CF Models). . . . .	pg10
Circulator (CF Model) Assembly. . . . .	pg10
Control Panel Installation. . . . .	pg12
C-25 Timer Control Instructions. . . . .	pg14
C85 / C95 non-metallic Wiring Diagram. . . . .	pg15
3 Phase Startup Procedure. . . . .	pg16
C85 / C95 non-metallic and 3 Phase Control Panel Timer. . . . .	pg17
2400, 3400, 4400, 8400, 2.3 Replacement Parts Diagram. . . . .	pg18
3HP & 5HP Replacement Parts Diagram. . . . .	pg19
Maintenance Recommendations. . . . .	pg20
Warranty Policy. . . . .	pg20
Troubleshooting Tips. . . . .	pg21
Customer Repair Form. . . . .	pg23
Registration Information. . . . .	pg24



3020379  
ANSI/UL 778, 5th Ed. 2010  
CAN/CSA C22.2 No. 108-M89  
UL 50, 11th Ed. 1995

Kasco Marine, Inc.  
800 Deere Rd.  
Prescott, WI 54021  
PH 715-262-4488  
FAX 715-262-4487  
sales@kascomarine.com  
www.kascomarine.com

Thanks!

We at Kasco Marine, Inc. would like to both thank and congratulate you on your purchase of the Pond Aerator or Water Circulator model. We appreciate you choosing Kasco and for your purchase. Your decision to purchase Kasco's Pond Aerator or Water Circulator will not disappoint you. The Pond Aerator or Water Circulator will be a great addition to your body of water. It will help improve the water quality by adding much needed oxygen and circulation. We thank you for choosing Kasco for your aeration needs and want you to be completely satisfied with your purchase.

### **Important Safety Instructions**

Please read and follow these extremely important safety and handling instructions for your Kasco equipment. Following these instructions will help ensure your safety and the quality performance of your equipment.

- Under NO circumstances should anyone enter the water with the electrical equipment plugged in and/or in operation. All Kasco equipment is ETL approved to UL and CSA standards for safety in water. However, it is NEVER recommended to enter the water with the equipment in operation.
- Caution should be used when dealing with any electrical and/or moving equipment.
- NEVER run the unit out of water. It will damage the seals and create a dangerous situation for the operator.
- Extreme caution should be used around water, especially cold water, such as in Spring, Fall, and Winter, which poses a hazard in and of itself.
- NEVER lift or drag the pond aerator or water circulator by the power cord. If you need to pull the unit to the side of the pond, use the anchoring ropes.
- Do not use waders in deep ponds/lakes or ponds/lakes with drop-offs, drastic slopes, or soft bottom material.
- Do not use boats that tip easily for aerator installation, such as a canoe, and follow all boating safety rules and regulations, including wearing a PFD (Personal Flotation Device).
- Single phase Pond Aerators or Water Circulators are supplied with an internal grounding conductor and a grounding-type attachment plug. To reduce the risk of electrical shock, be certain that the pond

aerator or water circulator is plugged into a GFI protected circuit.

- 3 phase aerators (2.3, 3.3, 5.3) require a startup test after wiring to ensure proper rotation of the propeller. If the propeller is rotating in the opposite direction, the unit will not perform properly and internal damage to the unit may occur. (See 3 phase startup procedure)
- Control panels must be installed a minimum of 5ft(3m in Canada) from the inside wall of the pond, unless separated from the body of water by a fence wall, or other permanent barrier that will make the unit inaccessible to persons in the water.
- Control panels must be installed by a qualified electrician.
- Ground Fault Circuit Interrupters (GFCI) should be tested upon each installation and every month thereafter to ensure proper operation.

### **General Owner's Instructions**

#### **INSPECT THE SHIPMENT**

Immediately inspect your Kasco Aerator shipment for any visible damages. Also cross reference the parts supplied with the Parts Included sheet to check for shortages. Shortages should be reported immediately to your Kasco Marine distributor or representative and damages reported to your carrier and Kasco Marine.

#### **CAUTION**

**WARNING:** Under NO circumstances should anyone enter the water with the unit in operation. Always operate the unit in the water and keep people and objects clear of the propeller. Do not lift or pull the unit by the electrical cord. Always use extreme caution around electrical equipment and water situations.

#### **ASSEMBLY & INSTALLATION**

Please see the proper Assembly and Installation Instructions enclosed in this manual. Each is specific for your model and size of Aerator. Note: It is extremely important to test the GFI breaker in the control panel upon each installation/reinstallation of the unit to ensure proper functioning.

#### **WARRANTY**

Kasco Aerators are the result of over 35 years of design and engineering. Kasco products are built to withstand the toughest conditions. Kasco Marine backs each Pond Aerator and Water Circulator with a

2 Year Warranty or 3 Year Warranty depending on the model. This warranty covers any and all manufacturer defects within the warranty period from the date of purchase (See Warranty, Warranty Claim, & Return Policy). Please register your Aerator online at: [www.kascomarine.com](http://www.kascomarine.com) (under the technical tab)

### USE AND OPERATION

Kasco Aerators are designed and engineered for continuous duty, such as on fish farms or other aquaculture applications, or on-demand use, as needed in a recreational water feature.

During flotation operation, the water is pulled from 360° around the unit and from below the unit. The water is pulled upward and thrust through the flotation collar into the air.

Your Kasco Marine Aerator is ready for immediate use (after installation). Make sure to keep the motor housing clean from hard water deposits and/or algae. (See Maintenance Recommendations.)

Kasco Pond Aerators and Water Circulators are lightweight, energy efficient, and easy to install and operate. We strive to produce products that exceed customer expectations. We hope you enjoy your Kasco Pond Aerator or Water Circulator.

### Unit Specs

Model	Voltage	Operating amps	lock rotor amps
single phase aerators			
2400AF	115	5 @115V	12@115V
3400AF	115	6.7 @115V	18@115V
3400HAF	208-240	3.4 @240V	9@240V
4400AF	115	11.3@115V	40@115V
4400HAF	208-240	5.7@240V	20@240V
8400AF	208-240	9.0 @240V	40@240V
3.1AF	208-240	10.7 @240V	63@240V
5.1AF	208-240	18 @240V	97@240V
3 phase aerators			
2.3AF	208-230	4.5 @ 230V	40
3.3AF	208-230	8.2 @ 230V	70
5.3AF	208-230	13 @ 230V	100
Single phase circulators			
2400CF	115	5@115V	12@115V
3400CF	115	6.7@115V	18@115V
3400HCF	208-240	3.4@240V	9@240V
4400CF	115	11.3@115V	40@115V
4400HCF	208-240	5.7@240V	20@240V
8400CF	208-240	9.0@240V	40@240V
2.3HAF	460	2.3 @ 460V	20

Model	Voltage	Operating amps	lock rotor amps
3.3HAF	460	4.1 @ 460V	35
5.3HAF	460	6.5 @ 460V	50
Single phase circulators			
2400CF	115	5@115V	12@115V
3400CF	115	6.7@115V	18@115V
3400HCF	208-240	3.4@240V	9@240V
4400CF	115	11.3@115V	40@115V
4400HCF	208-240	5.7@240V	20@240V
8400CF	208-240	9.0@240V	40@240V

### 2400AF, 3400AF/HAF, 4400AF/HAF Parts

Included:

1. Aerator (Unit with cord or unit with Disconnect(1)
  2. Float (with three 50' mooring ropes attached) (1)
  3. 1/4-20 x 3 1/2" Phillips Pan Head Screw (4)
  4. 1/4" split washers (4)
  5. 1/4" (3/4" outer diameter) Flat Washer (4)
  6. Float Retaining Clips (4)
- Optional: May be sold separately (bottom screen installation parts 7-12)
7. 3/8"-16 x 1-3/4" Hex Head Bolt (2)
  8. 3/8" Flat Washer (4)
  9. Bottom Screen cushions (3)
  10. Bottom Screen (1)
  11. Bottom Screen Clips (2)
  12. 3/8"-16 Nylon Lock Nut (2)

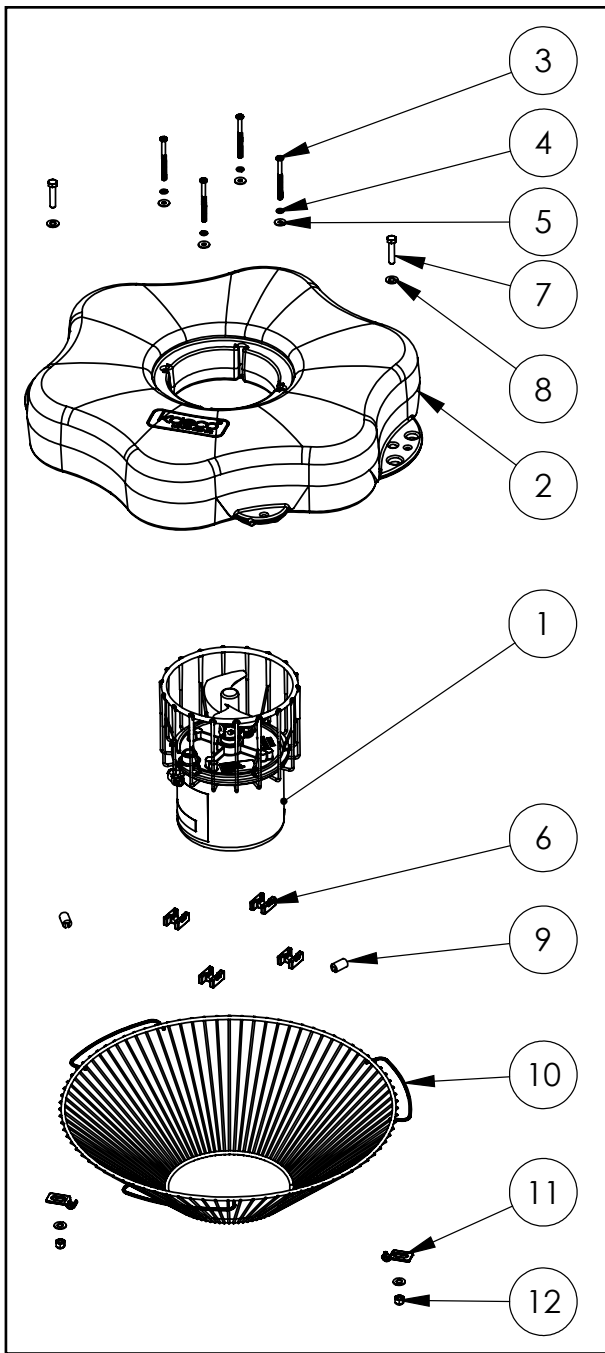

- tional C-25 (3) or C-85 (4)
- 9/16" Socket and Ratchet (for optional bottom screen)
- 9/16" Wrench (for optional bottom screen)
- Nylon Tie for cord

### 2400AF, 3400AF/HAF, 4400AF/HAF Assembly

#### STEP ONE

Make sure you have all the parts needed. If any shortages are found, contact your Kasco representative immediately.

#### STEP TWO

Set motor housing upright (stainless steel can down) on a flat surface. With motor housing upright, slide Float (Part 2) over pump housing making sure the surface with the Kasco logo is up.



Rest the float on the cage top ring.

#### STEP THREE

Ensure correct alignment by twisting the float gently around the motor housing until the power cord guide lines up with the cord. See diagram of bottom side of float.

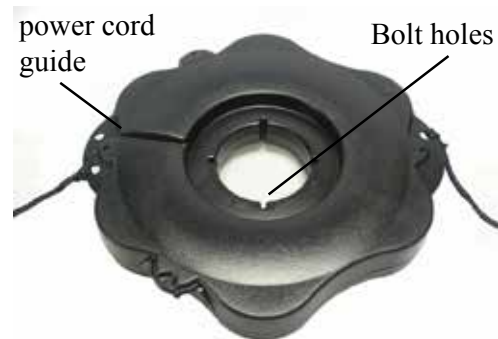

#### STEP FOUR

Use one of the 1/4"-20 x 3-1/2" Phillips Pan Head Screws (Part 3), one 1/4" split washer (Part 4), and a 1/4" Flat Washer (Part 5) to secure the float. Make sure the split washer goes between the bolt head and

#### Optional Equipment

- Control Box (C-25 for 120V units or C-85 for 240V units in separate box) (1 - optional)
- Bottom Screen with mesh and Hardware for Small Float Ring (1 - optional)

NOTE: Extra hardware may be included.

#### POND AERATOR TOOLS & SUPPLIES NEEDED

- Anchors or stakes for installing unit (2 or 3 depending on unit)
- # 2 Phillips head screw driver
- Two (or 3 depending on model) 12" pieces of 1" galvanized pipe for weighting ropes (optional)
- #10 x 1" long or longer screw(s) for mounting the op-

the flat washer. Insert screw with washer through bolt hole in float

Use one float retaining clip (Part 6) under the top ring of the cage. There is a U-shaped indent in the clip that will fit snug against the top ring of the cage. The 1/4"-20 x 3-1/2" will then thread into the retaining clip.

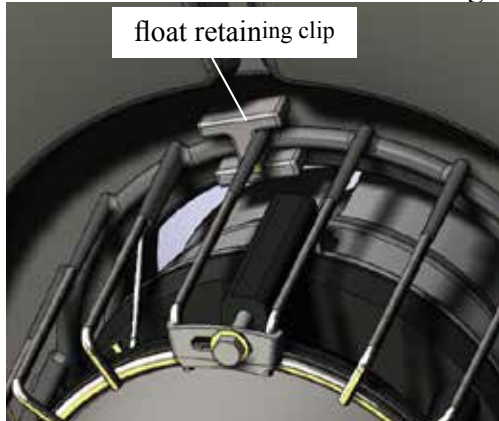

Tighten until snug with a Phillips Head screw driver and repeat for 3 remaining screws.



#### STEP FIVE (optional bottom screen)

See "Mesh Screen Attachment" section before connecting the bottom screen to the float. Turn secured assembly upside down so the top of the float (logo side) is face down on the flat surface. Place Bottom Screen (Part 10) onto the bottom side of the float. Make sure the wide opening of the screen is against the float and the 3 handles on the screen do not interfere with the rope placements. Fit the 3 Bottom Screen cushion (Part 9) underneath the screen and on top of the 3 spacing bumps on the bottom of the float.

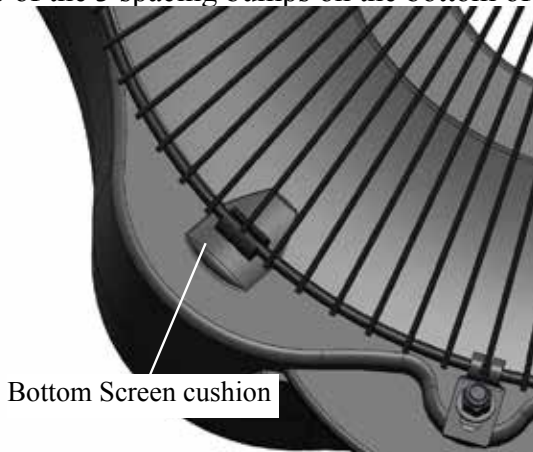

#### STEP SIX (optional bottom screen)

Using a stainless steel Bottom Screen Clip (Part 11), 3/8"-16 x 1-3/8" Bolt (Part 7), two 3/8" Flat Washer (Part 8), and 3/8"-16 Nylon Lock Nut (Part 12) to secure the screen to the float. Align a clip so the two prongs straddle a wire on the screen. Insert bolt with washer so the top of the bolt is facing the top of float (now in down position). Place the second washer and the locking nut with nylon insert on the end of the bolt and tighten using the 9/16" (14mm) Socket and Ratchet on the nut end and the 9/16" (14mm) Wrench on the bolt end. Tighten until snug and repeat with remaining clip.



#### STEP SEVEN

Turn the assembly upright again. At this time, if the cord contains a metal strain relief, you can use the chain connector and attach it in one of the opening at the rope placement. The chain connector will easily fit if installed from the bottom or top side of the opening. It will not fit if installed from side of opening. Use the Nylon Cable Tie included to secure the power cord to a molded hole in the float to prevent cord damage if there is no strain relief on the cord. If a Strain Relief is present on the cord, you may disregard the Nylon Tie. On cords with a Quick Disconnect, the disconnect should be tightened properly to avoid leaking. If installing a new Quick Disconnect, refer to Quick Disconnect Instructions.



#### STEP EIGHT(optional)

Thread one rope through one Pipe Weight and position it approximately 6' from the float. Next, thread the end of the rope back through the opening facing the float (as shown). Repeat with the second rope and weight. If ready to install in the pond, go to Installation instructions. Light Kits can also be installed at



this time, go to Light kit instructions.



- 9/16" & 7/16" Nut Driver
- 9/16" & 7/16" Socket
- Adjustable crescent wrench
- Nylon Tie for cord

8400AF, 2.3AF

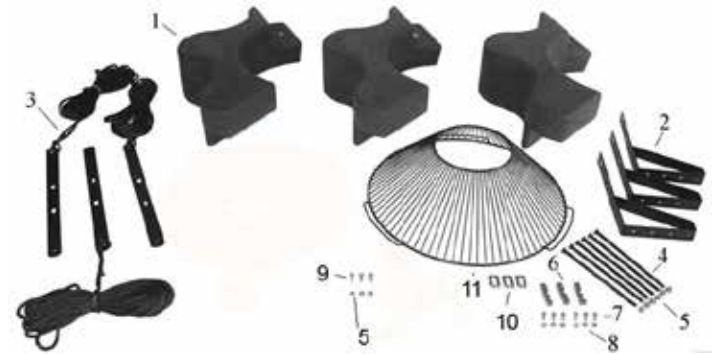

3.1AF, 3.3AF, 5.1AF, 5.3AF

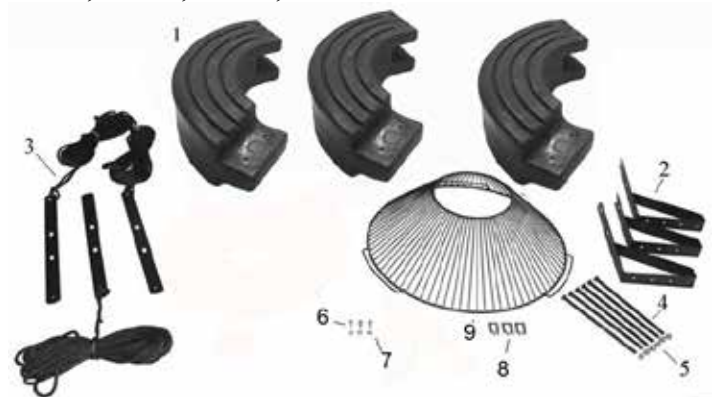

Tools & Supplies Needed:

- A. Anchors or stakes for installing unit (2 or 3 depending on unit)
  - B. 208-240V Electrical Supply near pond on a post
  - C. Two (or 3 depending on model) 30cm pieces of 2.54cm galvanized pipe for weighting ropes (optional)
  - D. 9/16" (14mm) & 7/16" (11mm) Nut Driver
  - E. 9/16" (14mm) & 7/16" (11mm) Socket
- Adjustable crescent wrench

## 8400AF, 2.3AF, 3.1AF, 3.3AF, 5.1AF, 5.3AF Assembly

### STEP ONE

Remove all contents from package and place on a clean, flat surface. Inspect the shipment for any damages. If damages are found, immediately notify your carrier and your Kasco Marine, Inc. representative. Next, cross reference the parts included in the shipment with the Parts Included sheet in this manual. Make sure you have all the parts needed. If any shortages are found, contact your Kasco representative

## 8400AF, 2.3AF, 3.1AF, 3.3AF, 5.1AF, 5.3AF Parts

### POND AERATOR PARTS INCLUDED

Aerator Unit with cord (Cord may be shipped separately) (1)

B. Large Float Ring (8400AF, 2.3AF)

1. Float Sections (3)
  2. Top Float Bracket (3)
  3. Bottom Float Bracket w/Rope (3)
  4. 9.5" x 3/8" Bolt (6)
  5. 3/8" Lock Nut (6)
  6. Unit Mounting Bracket (3)
  7. 1/4" x 3/4" Bolt (6)
  8. 1/4" Lock Washer (6)
  9. 1/4" x 3/4" Bolt with lock washers and nuts (3)
- Optional: (parts 10-13) May be sold separately

10. Bottom Screen Clip (3)

11. Bottom Screen (1)

12. Mesh screen (1)

13. Cable ties for mesh (10)

B. Large Float Ring (3.1AF, 3.3AF, 5.1AF, 5.3AF)

1. Float Sections (3)
  2. Top Float Bracket (3)
  3. Bottom Float Bracket w/Rope (3)
  4. 9.5" x 3/8" Bolt (6)
  5. 3/8" Lock Nut (6)
  6. 3/8" x 1" Bolt (3)
  7. 3/8" Lock Washer (3)
- Optional: (parts 8-11) May be sold separately

8. Bottom Screen Clip (3)

9. Bottom Screen (1)

10. Mesh screen (1)

11. Cable ties for mesh (10)

Optional Equipment

C. Control Box (1 - optional)

NOTE: Extra hardware may be included.

### POND AERATOR TOOLS & SUPPLIES NEEDED

- Anchors or stakes for installing unit (3)
- Philips head screw driver for mounting optional control panel
- 120V or 240V Electrical Supply near pond on a post
- Three 12" pieces of 1" galvanized pipe for weighting ropes (optional)
- #10 x 1" long or longer screw(s) for mounting the optional C-25 (3) or C-85/95 (4)

immediately.

#### STEP TWO

Arrange the three Float Sections (Part #B1) upright (plug on bottom) so the overlap of one section aligns with the next section and loosely push the three sections together to form a continuous ring.

8400AF, 2.3AF

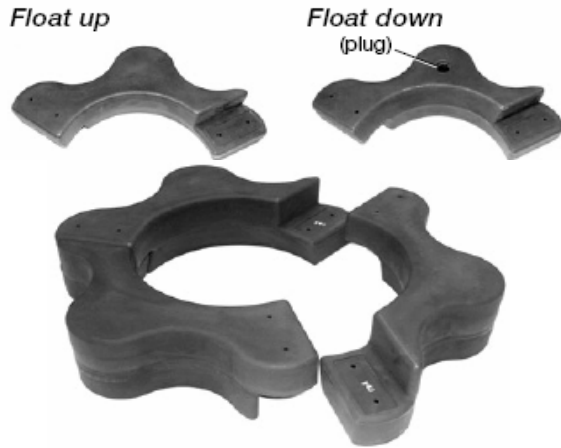

3.1AF, 3.3AF, 5.1AF, 5.3AF



#### STEP THREE

Position one Top Float Bracket (Part #B2) so that the bolt holes in the bracket align with the bolt holes in the two adjoining float sections and insert two 9.5" Coated Bolts (Part #B4) through the assembly. This may require some minor repositioning of the float sections as you push the bolt all the way through. Do not force the bolt through. Repeat for the remaining two joints.



#### STEP FOUR (8400, 2.3)

Turn the assembly upside down and place the Bottom

Float Brackets (Part #B3) over the bolts, the ends of which should now be extending through the assembly. Loosely install the six 3/8" Lock Nuts (Part #B5) on the ends of the bolts (do not tighten yet). Connect the Top and Bottom Float Brackets using three 1/4" x 3/4" Bolts (Part #B9) with three lock washer and 1/4" nuts and tighten using the 7/16" wrench and socket.

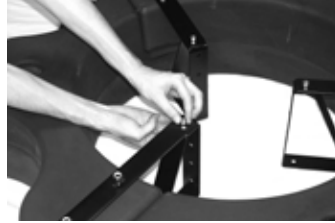

Attach the Unit Mounting Brackets (Part #B6) loosely to the float bracket with (3) 1/4" x 3/4" bolts and 1/4" Lock Washers in the top mounting hole as shown



#### STEP FOUR (3.1, 3.3, 5.1, 5.3)

Turn the assembly upside down and place the Bottom Float Brackets (Part #B3) over the bolts, the ends of which should now be extending through the assembly. Loosely install the six 3/8" Lock Nuts (Part #B5) on the ends of the bolts (do not tighten yet).



#### STEP FIVE

See "Mesh Screen Attachment" section before connecting the bottom screen to the float. If the optional Bottom Screen (Part#B11) was purchased, place the Aerator Assembly inside the bottom Screen as shown.



**STEP SIX (8400,2.3)**

Lift Float Assembly and place over Aerator Assembly. Adjust one unit Mounting Bracket at a time and nest the cage ring in the lower notch of the Unit Mounting Bracket for the 3.1, and 5.1 units. Nest the cage ring in the middle notch of the Unit Mounting Bracket for the 8400.

8400, 2.3



Once all three Unit Mounting Brackets are seated correctly on the cage ring, add remaining 1/4" x 3/4" Bolts and 1/4" Lock Washers to lower mounting hole. Tighten all bolts on the Unit Mounting Bracket with 7/16" socket or wrench.

**STEP SEVEN (Optional Bottom Screen)**

Raise the Bottom Screen and secure with Bottom Screen clips. Remove the center three 3/8" Lock Nuts from the 9" Bolts and place the Bottom Screen Clips (Part #B10) over the bolts as shown. The power cord can be slid under the bottom screen between the float and screen where two float sections come together before the 3/8" Lock Nuts are replaced. Replace the three inside Lock Nuts and tighten all 3/8" Lock Nuts using the 9/16" wrench and socket.



*Note: Extra hardware may be included*



**STEP EIGHT**

On power cord lengths of 100 feet or longer with the watertight Quick Disconnect, the power cord is shipped separately. It should now be attached to the stub cord by lining up the male and female halves of the disconnect and hand tightening the blue collar. On these cords, the Additional Strain Relief should be attached to one of the lower float brackets as pictured. If you receive a 3 chain strain relief (6 or 8 gauge cord), attach one chain to each of the three lower float brackets. If there is not Strain Relief, use the Nylon Cable Tie provided to secure the cord to a rope to prevent damage by the propeller. Double check the Quick Disconnect to make sure the threaded collar has not come loose in shipping before placing in the water. If installing a new Quick Disconnect, please refer to Quick Disconnect instructions.

**STEP SIX (3.1, 3.3, 5.1, 5.3)**

Lift Float Assembly and place over Aerator Assembly. Place the 3/8" x 1" Bolts (Part #B6) and 3/8" Lock Washers (Part #B7) through the top float bracket and lower float bracket as shown and screw directly into the aerator mounting ring. Tighten down with a 9/16" wrench.



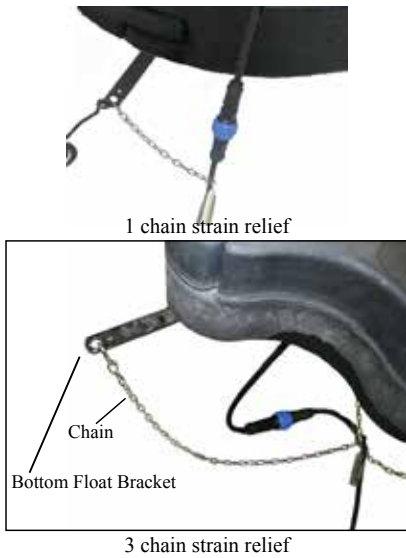

## Mesh Screen Attachment

1. Take flat mesh pattern and wrap into cone shape by overlapping both vertical edges by approximately 1 inch and aligning top and bottom edges of mesh. Secure mesh vertical seam at the top, bottom and middle using (3) cable ties.

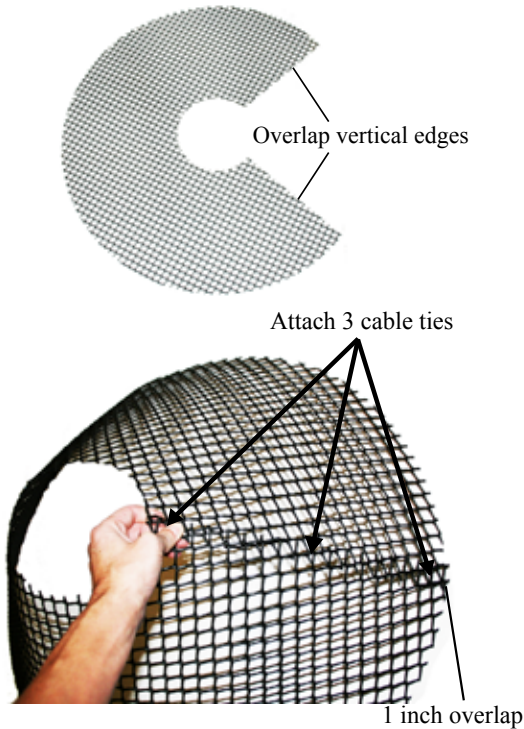

2. Insert existing stainless steel screen centered inside mesh cone with approximately 2 inches of mesh overlap to the top ring of the screen. Attach mesh



to the top ring of the screen in (3) equally spaced locations using cable ties.

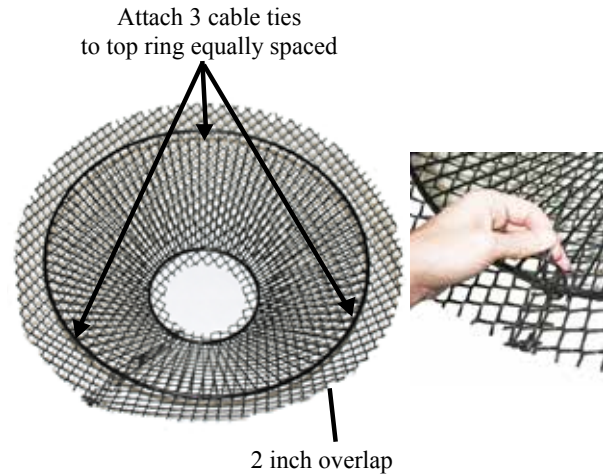

3. Flip mesh and screen assembly over and use remaining cable ties to secure mesh to small bottom diameter of the stainless steel ring.

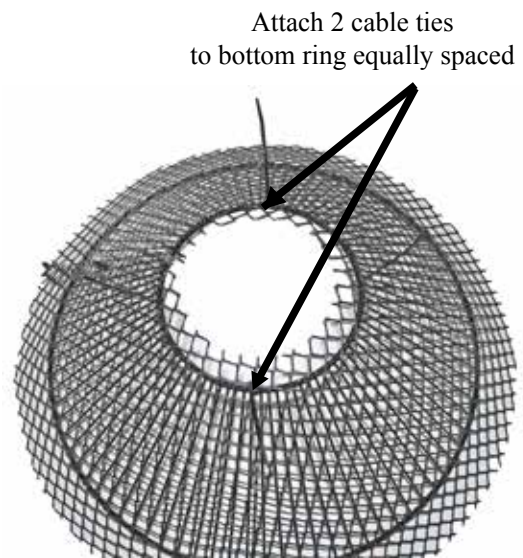

4. Clip off excess cable tie material once mesh is secured into place. Go back to assembly instructions to continue with connecting the bottom screen to the float.

## Installation Instructions

Before installing 3 phase units (2.3, 3.3, 5.3) into the pond, please refer to 3 phase startup procedure.

### STEP ONE

Use the ropes to position the Aerator in the desired location in the pond/lake. Anchor the ropes or secure them to the shoreline so the ropes are free of slack, but not tight. To prevent twisting of the unit due to torque, you should place the anchor at least 3 feet from the

float for each foot of depth (Ex. A 6 foot deep pond would require an anchor 18 feet horizontally from the float.)

For ease of removal, you may choose to keep at least one anchor within reach from shore, just below the water's surface.

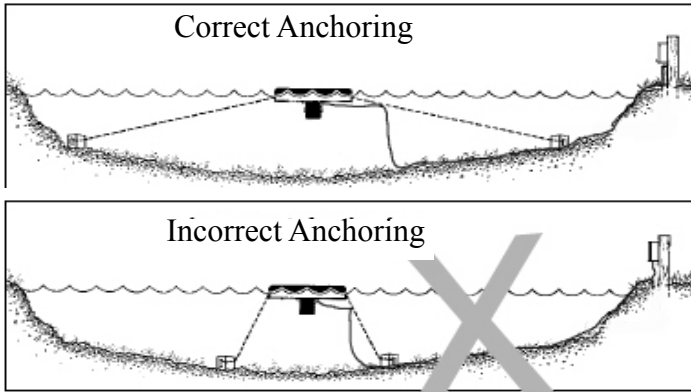

### STEP TWO (ALTERNATE INSTALLATION)

In ponds where the water level fluctuates significantly, you may need to suspend a small weight (12" of 1" galvanized pipe works well) at the mid-point of the rope to take up any slack as the water level drops. The weight should be light enough so the Aerator can rise as the water level rises. This can also help hide ropes by sinking them further below the surface.

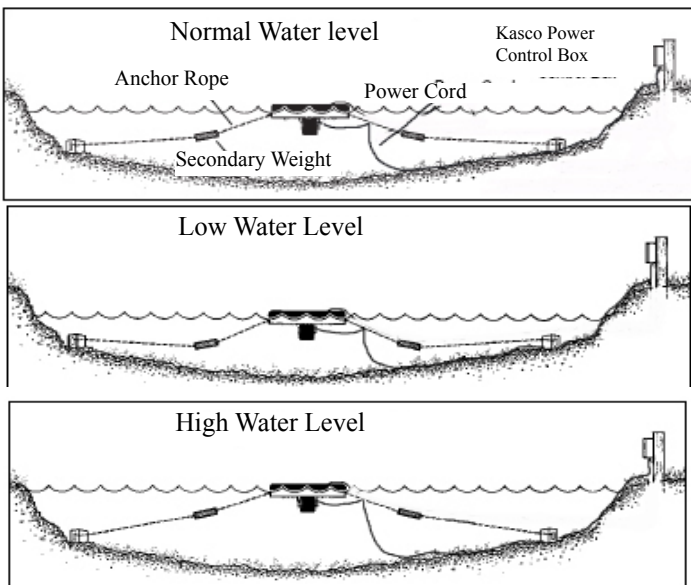

### STEP THREE

At this time the Aerator is ready for operation. It can be plugged into the power supply at the pond edge. ENJOY YOUR NEW KASCO EQUIPMENT!

### Circulator Parts (CF Models)

- Circulator (Unit with cord or stub cord) (1)
- Float in separate box (1)
  1. Float (1)
  2. Base Strap (1)

3. Adjustment Bracket (1)
4. Angle Bracket (3)
5. Draw Band (1)
6. U-Bracket (2)
7. Spacer Bracket (2)
8. 1/4" x 1/2" Stainless Steel Bolt (8)
9. 1/4" x 1" Stainless Steel Bolt (3)
10. 1/4" x 1-1/4" Stainless Steel Bolt (2)
11. 1/4" Stainless Steel Lock Nut (8)
12. 1/4" Stainless Steel Hex Nut (2)
13. 1/4" Stainless Steel Lock Washer (5)
14. 50' Black Nylon Ropes (2)
15. Nylon Tie (1)

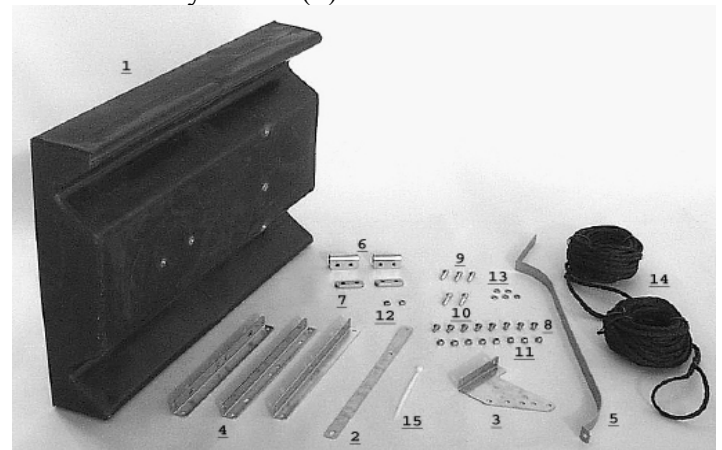

### Circulator Tools & Supplies Needed

- A. Anchors or stakes for installing unit (2)
- B. 120V or 240V Electrical Supply near pond on a post (1)
- C. 12" pieces of 1" galvanized pipe for weighting ropes (optional) (2)
- D. 9/16" (14mm) & 7/16" (11mm) Nut Driver
- E. 9/16" (14mm) & 7/16" (11mm) Socket
- F. Adjustable crescent wrench
- G. 7/16" Wrench (1)
- H. 7/16" Socket & Wrench (1)
- I. Felt-tip marker (1)

### Circulator (CF Model) Assembly

#### STEP ONE

Remove all contents from package and place on a clean, flat surface. Inspect the shipment for any damages. Make sure you have all the parts needed.

#### STEP TWO

Position the Float (Part B1) upside down (lengthwise channels facing up) and place the Base Strap (Part B2) so the three holes in the Base Strap align with the three threaded holes that comprise the lengthwise midline of the Float.

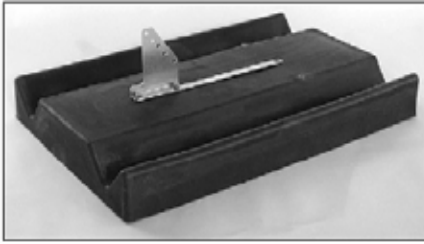

**STEP THREE**

Position the Adjustment Bracket (Part B3) over the two holes at the back end of the Float and Base Strap. Loosely secure the Adjustment Bracket to the Float using two 1/4" x 1/2" (Part B8) Stainless Steel Bolts and two Stainless Steel Lock Washers (Part B13). (See photo above for orientation.)

**STEP FOUR**

Place one of the three Angle Brackets (Part B4) perpendicular to the Base Strap at the front end of the Base Strap. One of the two center holes of the Angle Bracket should be positioned over the hole in the Base Strap and the threaded hole in the Float. Secure the Angle Bracket to the Float using three 1/4" x 1/2" Stainless Steel Bolts and three Stainless Steel Lock Washers. (See photos in the next column for specific instructions based on the size circulator purchased.) Tighten all hardware at this time with the 7/16" (11mm) socket and wrench.

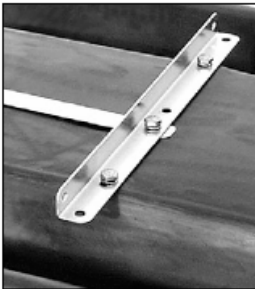

Models 2400 & 3400 - Angle posterior to bolts.

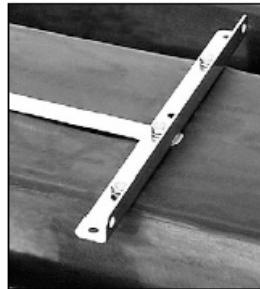

Model 8400 & 4400 Angle anterior to bolts.



**STEP FIVE**

With a felt-tip marker, draw three to four marks around the circumference of the motor housing at the appropriate measurement from the back (or bottom) of the motor housing given:

- 2400: 3/4" (1.9cm)
- 3400: 3-3/8" (8.57cm)
- 4400: 5-1/2" (14 cm)
- 8400: 7-1/2" (19 cm)



**STEP SIX**

Place the two U-Brackets (Part B6) directly across from each other (180°) over the top ring of the motor cage. The cord clamp on the cage should be 90° from each of the U-Brackets

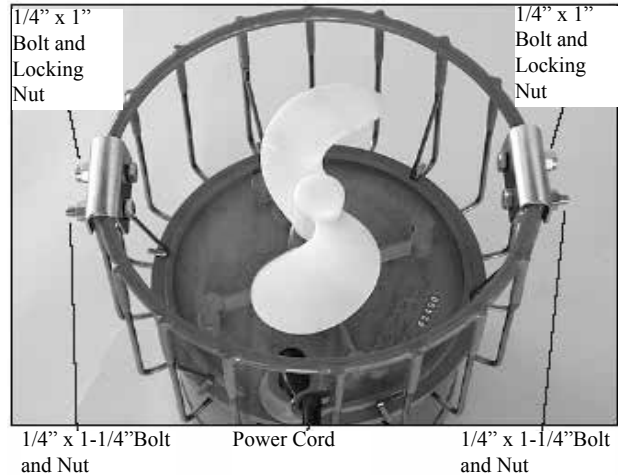

**STEP SEVEN**

Insert the Spacer Bracket (Part B7) under the U-Bracket and inside the cage. Secure this assembly using one 1/4" x 1" Bolt (Part B9) and a 1/4" Lock Nut (Part B11), and one 1/4" x 1-1/4" Bolt (Part B10) and a 1/4" Hex Nut (Part B12). The longer bolt should be on the side of the U-Bracket that is closer to the cord clamp. Tighten the hardware using the 7/16" (11mm) wrench and socket & wrench until the U-Bracket clamps firmly around the cage (U-Bracket should pull together slightly). Repeat with the second U-Bracket.



**STEP EIGHT**

Attach an Angle Bracket to each of the longer (1-1/4") bolts on the U-Brackets (See photo for orientation) with a 1/4" Lock Nut.



2400 & 3400

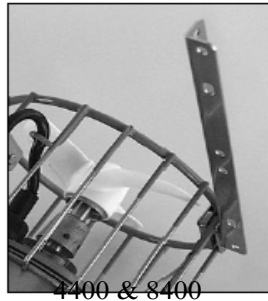

4400 & 8400



Horizontal



Angled Up

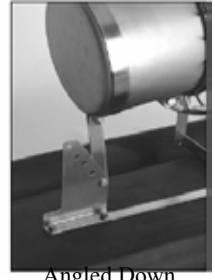

Angled Down

**STEP NINE**

Wrap the Draw Band (Part B5) around the motor housing and position so that the back of the Draw Band touches the marks drawn in Step Five. There is no front or back to the Draw Band itself - it is reversible. Orient the arm of the Draw Band so it aligns with the cord clamp on the cage of the motor housing and is parallel to the Angle Brackets attached in Step Eight. Secure using a 1/4" x 1" Stainless Steel Bolt and a 1/4" Lock Nut. (See photo in next column)



**STEP TEN**

Attach the Angle Bracket on the motor to the Angle Bracket on the Float using two 1/4" x 1/2" Bolts and two 1/4" Lock Nuts (one set for each Bracket). See photos for orientation based on model size. Also, the cord clamp on the cage should be oriented toward the Float.

Angle towards back      Angle Towards front



2400 & 3400



4400 & 8400

**STEP ELEVEN**

Attach the Draw Band on the motor to the Adjustment Bracket on the Float using a 1/4" x 1/2" Bolt and a 1/4" Lock Nut. Select one of the five possible positions to mount the Draw Band for your preferred direction of flow. We do not recommend the two outer (most upward and most downward) mounting positions for 8400 models.

**STEP TWELVE**

Attach the Ropes to the front (on the cage) and back (around the Draw Band) of the motor. At this time, use the Nylon Tie provided to connect the power cord and front Rope to prevent the cord from tangling in the prop. Also, if the power cord has a Quick Disconnect and Additional Strain Relief install the Quick Disconnect and Strain Relief per instructions.



**STEP THIRTEEN**

Float the circulator in the water and position where desired. Tie the front Rope to a stake on the shore or weight. If a weight is used sink weight in front of unit so rope is taught. (Circulators create great force, make sure weight is enough to prevent movement.) Tie back Rope to a stake on opposite shore or weight. Sink weight behind the unit so rope is taught. At this time take up any slack in the line.

**STEP FOURTEEN**

You can now connect the Circulator into the GFI protected power source at the ponds edge.

**Control Panel Installation**

**STEP ONE**

Inspect the panel for any damage and any components that may have loosened during shipping.

Control panel must be installed a minimum of 5ft (3m in Canada) from the inside wall of the pond, unless separated from the body of water by a fence wall, or other permanent barrier that will make the unit inaccessible to persons in the water.

Install the control panel to a post structure, side of a



building, or other reliable means. This structure must support the panel and prevent movement/flexing of the panel. Use #10 x 1" or longer screws in the mounting points of the control panel to secure to the post structure.

NOTE: The control panel must be hung upright in order to be waterproof. It is also advised to mount the panel out of direct sunlight if possible. Mounting the panel in a North direction will prevent heat buildup inside the panel. Also, mount the panel above the potential flood plain to prevent water entry during a possible flood event.

#### STEP TWO

Set Timer in the control panel to desired ON and OFF times per the Instructions for each specific timer.

#### STEP THREE

**Follow all local and national electrical codes for this installation and Consult a qualified electrician or service person if needed.**

(For 120V Installations)

Plug the aerator cord into the C-25 outlet labeled "UNIT". If lights are included, plug the Transformer cord into the C-25 outlet labeled "LIGHT". Now you are ready to plug the C-25 into the 120V power supply on the post and ENJOY YOUR NEW KASCO AERATOR!

3 Phase: (2.3, 3.3, 5.3)

Refer to your 3 phase control panel instructions

Single Phase: (3400H, 4400H, 8400, 3.1, 5.1)

#### STEP THREE (For 240V Installation)

All electrical connections to this panel must be made with proper strain relief cord grip fittings or with conduit connections as required by local and national electric codes. The bottom of the enclosure is reserved for field installation of these connections.

#### **C85 / C95 non-metallic control panel:**

*Incoming power connection: (Power feed)*

This control panel requires a 240V or 208V - 4 wire service (L1, L2, N, & G) and must be fed with a power circuit protected by a circuit breaker or a fused disconnect switch to provide circuit protection and a disconnection means.

C-85 panel requires at least a 30amp protected circuit feeding the panel.

C-95 panel requires at least a 40amp protected circuit feeding the panel.

Connect your power feed as detailed in the wiring diagram provided with this panel.

L1 connects to Terminal #1

L2 connects to Terminal #2

N connects to Terminal N

G connects to Terminal GROUND - located on chassis plate

Be sure to provide adequate sized power conductors to prevent excessive voltage drop. Consult with your electrician to properly size power feed conductors. Use copper conductors only.

#### *Aerator power cord connection:*

Your aerator (pump) will be provided with a flexible power cord for connection to this control panel. If the power cord has a plug, you will need to cut it off. The power cord conductors (black, white, green) will need to be stripped back 1/2". The outer black jacket should be stripped back at least 3 inches. Follow the connection diagram for terminating these three wires to the terminal blocks in the control panel.

Black connects to Terminal #4

White connects to Terminal #5

Green connects to Terminal G

#### *Light Kit connection:*

If you purchased a Kasco light kit(s) for your aerator, follow the light kit installation instructions for mounting the light kit(s) to the aerator float.

This control panel requires a hardwire connection for the light kit(s). To connect the light kit(s) you will need to cut off the power cord plug that is molded to the light kit power cord. Strip back the black outer jacket of the light kit power cord at least 3 inches to reveal the three internal wires of the power cord. (black, white, and green conductors). These three wires will need to be stripped back 1/2". Follow the connection diagram for terminating these three wires to the terminal blocks in the control panel.

#### Light kit connections:

Black connects to Terminal #6

White connects to Terminal #7

Green connects to Terminal G

#### STEP FOUR:

**Test the GFCB with the test button now and every 30 days.**

If lights are installed, they can now be installed per Instructions included with the lights.

Once completed, power can be restored to the panel.



**Record the following data while the Aerator is operating in the water under load:**

**Voltage:**

**L1-L2** \_\_\_\_\_

**L1-N** \_\_\_\_\_

**L2-N** \_\_\_\_\_

**Amperage:**

**L1** \_\_\_\_\_

**L2** \_\_\_\_\_

**Date installed** \_\_\_\_/\_\_\_\_/\_\_\_\_

Any unauthorized modifications to this control panel will void the UL listing and the Kasco warranty.

## **C-25 Timer Control Instructions**

(Optional Equipment)

Portable Timer with Ground Fault Interrupter  
**IMPORTANT**

This portable timer is designed for CONTROLLING the connected equipment only. Unplug timer before servicing the unit or the equipment it controls. THE MANUAL OVERRIDE KNOB IS NOT TO BE USED AS A POWER DISCONNECT! For maximum protection against electrical shock hazard, perform test procedure on G.F.C.I. at least once a month. Mount at least 5 ft. from open water.

### **G.F.C.I. TEST PROCEDURE**

The G.F.C.I. should be checked every month to make sure that it is operating properly. Just follow the simple instructions below. It is recommended to maintain a maintenance diary of your monthly safety check.

1. Push TEST button, RESET button should pop out from inner surface. This should result in power being OFF at the outlet protected by the G.F.C.I. Verify by plugging a test lamp into the outlet. Be sure the timer is in the ON position.
2. If the G.F.C.I. tests okay, restore power by pushing the RESET button back in. THE RESET BUTTON MUST BE PUSHED FIRMLY AND FULLY INTO PLACE UNTIL IT LOCKS AND RE-MAINS DEPRESSED AFTER PRESSURE HAS BEEN REMOVED.

**DANGER: IF RESET BUTTON DOES NOT POP OUT, IF TEST LAMP REMAINS LIT WHEN RESET BUTTON**

**DOES POP OUT, OR IF THE G.F.C.I. FAILS TO RE-SET PROPERLY, DO NOT USE TIMER! CONTACT A QUALIFIED SERVICE TECHNICIAN!**

**UNDER NO CIRCUMSTANCES SHOULD ANYONE ENTER THE WATER WHEN A UNIT IS IN OPERATION!**

### **TIMER-OPERATION INSTRUCTIONS**

C-25 Control Box will turn the aerator ON & OFF with the TIMER. Kasco lights will turn ON with the PHOTO EYE and OFF with TIMER. C-25 Control Box is to be used with Kasco Approved Lights ONLY!

- Insert "ON" (GREEN) and "OFF" (RED) trippers into dial at desired ON and OFF times.
- Turn dial clockwise one or more revolutions until correct time-of-day (AM or PM) in window is aligned with the arrow.
- Plug aerator cord into the RIGHT hand outlet (labeled UNIT).
- Plug transformer light cord into LEFT hand outlet (labeled LIGHT).

### **FOR TEMPORARY MANUAL OPERATION**

Rotate MANUAL knob counter-clockwise to desired ON or OFF position. Timer will follow next automatic operation.

# C85 / C95 non-metallic Wiring Diagram

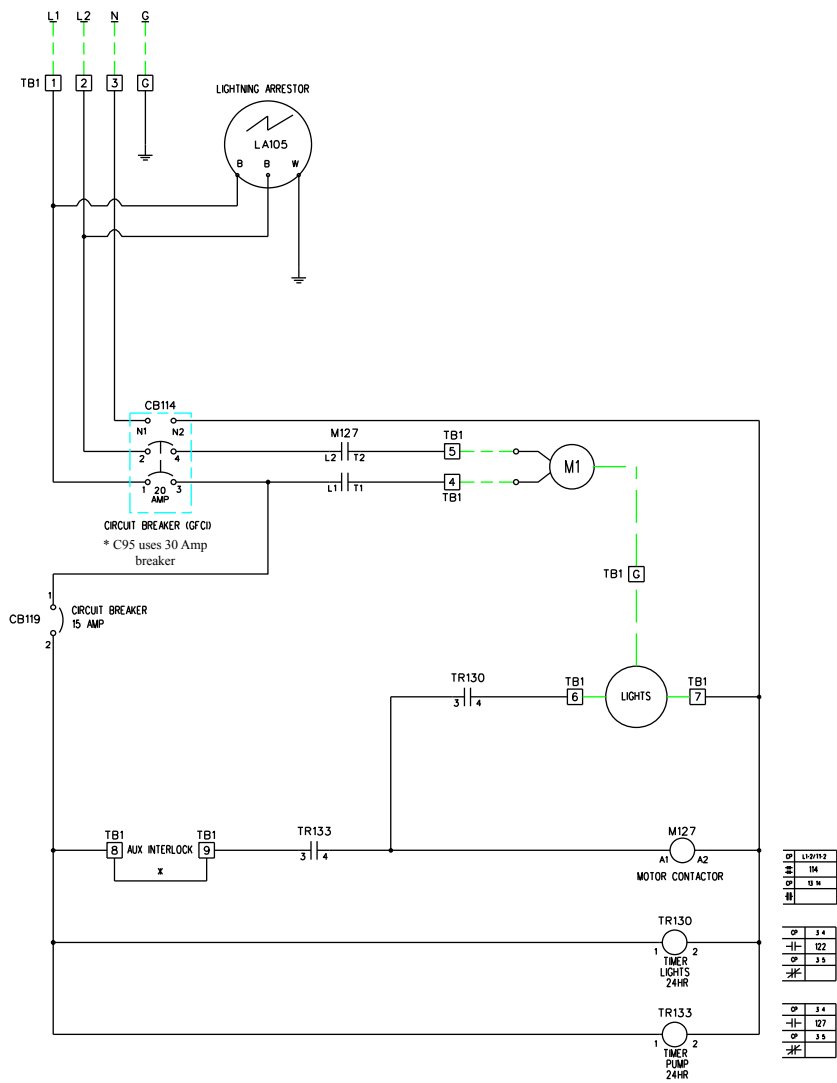

□	L12/112
□	114
□	115
□	116
□	117

□	114
□	117
□	115
□	116
□	117

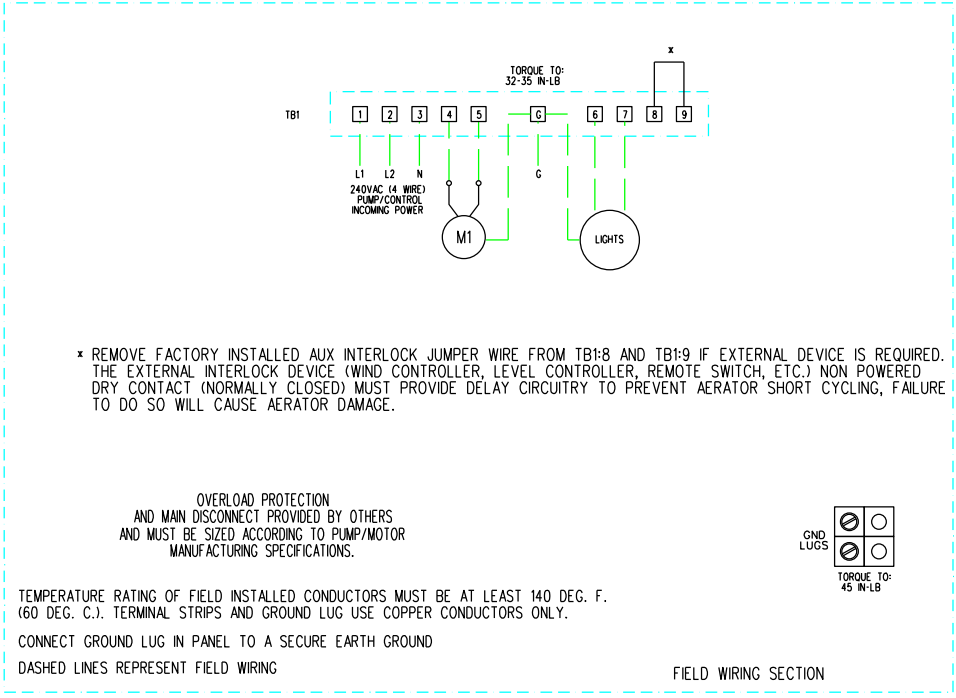

### 3 Phase Startup Procedure

If a Kasco Control Panel is not provided, please refer to the following warnings:

When inherent overheating protection is not provided: use with approved motor control that matches motor input in full load amperes with overload element(s) selected or adjusted in accordance with control instructions.

*Utiliser un démarreur approuvé convenant au courant à pleine charge du moteur et dont les éléments thermiques sont réglés ou choisis conformément aux instructions qui l'accompagnent.*

When inherent overheating protection is provided: use with approved motor control that matches motor input in full load amperes. See table below.

*Utiliser un démarreur approuvé convenant au courant à pleine charge du moteur.*

Note: The motor input in full load amperes is the marked value or the service factor amperes, shown on the nameplate.

3 phase 208-230 Volt	2.3AF	3.3AF	5.3AF
Full load amps	4.5	8.2	13.0

3 phase 460 Volt	2.3HAF	3.3HAF	5.3HAF
Full load amps	2.3	4.1	6.5

Control panels must be installed by a qualified electrician.

If unit is connected to a circuit protected by a fuse, use a time-delay fuse with this pump.

#### **You must verify motor rotation before installing the unit in the water.**

3phase Kasco units will run in a clockwise rotation when looking down at the propeller. Stand clear of the propeller while verifying rotation. If a Kasco 3 phase panel is supplied, follow the instructions with the panel. Also follow the steps below.

Electrician:

1. Verify all screw terminal connections are tightened to

- specified torque setting prior to energizing the panel.
2. Verify the electrical service (voltage and Phase) matches the control panel and aerator nameplates ratings. Refer to the control panel instructions and schematics for installation details.
3. Verify all switches, circuit breakers, and motor starters are in the OFF position
4. Connect electrical service to this control panel as shown in the electrical schematic that came with the panel.
5. Connect the Aerator power cord to this panel as shown in the electrical schematic.
6. Set the motor starter overload to the FLA rating on the aerator nameplate.
7. Pump rotation: The pump rotation is clockwise when looking down at the propeller. Apply power to the control panel. Turn on the 15amp control circuit breaker, and motor starter.
8. Momentarily turn the Hand-Off-Auto switch to Hand. This will run the aerator. Do not run the aerator for more than a few seconds on shore. If the rotation is not correct. Disconnect and lock out power from the control panel. Swap any two of the aerator power cord wires in the panel. This will cause the motor to reverse direction. Reapply power to the panel and verify the rotation is clockwise.
9. Once rotation is verified, with the power disconnected and locked out again, continue with installation of the aerator as detailed in the owner's manual.

Record the following data while the unit is operating in the water under load:

Voltage:	Amperage:
L1-L2 _____	L1 _____
L1-L3 _____	L2 _____
L2-L3 _____	L3 _____

Current unbalance should not exceed 5% at full load

# C85 / C95 non-metallic and 3 Phase Control Panel Timer

## TIME CLOCK SETTING

To set the current time, turn the inner dial clockwise. Do not set the time by rotating "outer" dial. Turn the minute hand or small plastic inner dial clockwise until the time of day on the outer dial is aligned with the triangle marker on the inner dial (two o'clock position). Example for 10:00 AM. Turn the minute hand clockwise until 10:00 AM is aligned with the triangle on the inner dial. The hour and the minute dial will show exactly 10:00.

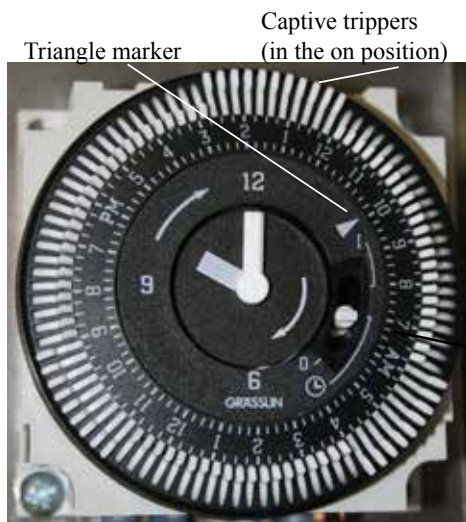

minutes for each tripper on the 24-Hour dial. When the tripper is pushed to the inside, the switch is in the "OFF" position.

## PROGRAMMING WITH MANUAL OVERRIDE SWITCH

Your Timer may have a 3-way manual switch or a 2-way manual switch.

### AUTOMATIC MODE

In order to operate the time clock in the automatic mode, the manual switch must be in the automatic position- see diagram.

### MANUAL MODE

For the 3-way switch, with the manual override switch in the lower position, marked "O", the time clock output will remain Permanently OFF. In the upper position, marked "I", the time clock output will remain permanently ON.

For the 2-way switch, with the manual override switch in the lower position, marked "ON" the time clock output will remain permanently ON.

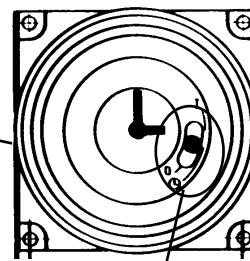

Override Mode	
3-way manual override switch	I = permanent ON ⊖ = automatic O = permanent OFF

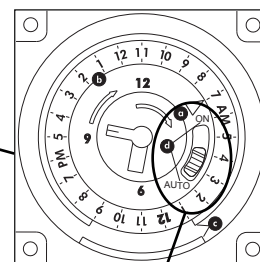

Override Mode	
2-way manual override switch	ON - Permanently ON AUTO - automatic

## PROGRAMMING

The 24-Hour dial has quarter-hour divisions and AM/PM indications. The time switch is programmed by pushing the captive trippers to the outer ring position for the entire period that the aerator is to be turned "ON", i.e., fifteen

## 2400, 3400, 4400, 8400, 2.3 Replacement Parts Diagram

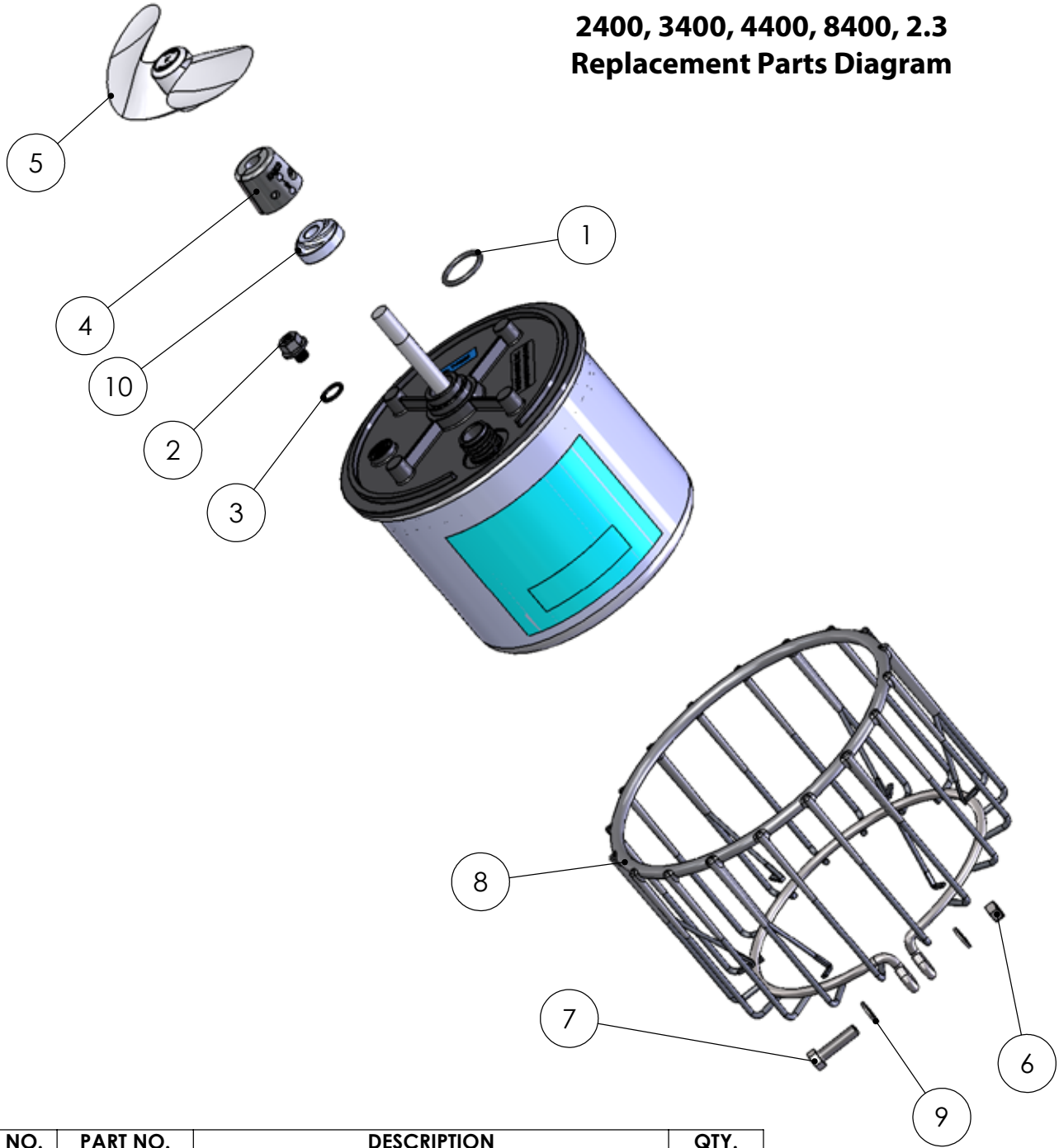

ITEM NO.	PART NO.	DESCRIPTION	QTY.
1A	990275	CORD O RING	1
2	990280	SEALING PLUG	1
3	990281	SEALING ORING	1
4A	243475	ZINC ASSEMBLY (2400 & 3400 MODELS)	1
4B	840475	ZINC ASSEMBLY (4400 & 8400 MODELS)	1
5A	240170	2400 K PROP (2400 MODEL)	1
5B	340125	3400 J PROP (3400 MODEL)	1
5C	440400	4400 M PROP (4400 MODEL)	1
5D	820450	8400 Y PROP (8400 MODEL)	1
6	261234	HEX NUT	1
7	261240	5/16-18 X 1 HHCS	1
8	990201	CAGE	1
9	261231	FLAT WASHER	2
10A	990410	DEBRIS FLINGER 1/2" (2400 & 3400 MODELS)	1



ITEM NO.	PART NO.	DESCRIPTION	QTY.
1	SEE CHART	PROP ASSEMBLY, 6 BLADE	1
2	475642	WASHER, 1/2"	1
3	840475	ZINC ASSEMBLY	1
4	990280	SEALING PLUG	1
5	990281	O RING	1
6A	990275	O RING, CORD	1
6B	990290	O RING, CORD (5.1)	1
7	140312	RETAINING CLIP	6
8	840537	LOCK WASHER, 1/4"	6
9	840539	1/4-20 x 3/4" HEX HEAD CAPSCREW	6
10	993300	RING, AERATOR MOUNTING	1
11	840510	DEBRIS FLINGER, .625 DIA. SHAFT	1

### 3HP & 5HP Replacement Parts Diagram



MODEL NO.	PROP NO.
3.1A	821114
3.3A & U3.3A	821114
3.3HA & U3.3HA	821115
5.1A	821124
5.3A & U5.3A	821124
5.3HA & U5.3HA	821124

## Maintenance Recommendations

Under No Circumstances should anyone enter the water while a unit is operating. Turn Off and Disconnect electrical power prior to any Maintenance or Servicing

Ground fault interrupters are a safety feature that can also alert you to electrical leaks in the equipment. It is extremely important to test the GFI upon installation, each reinstallation, and monthly thereafter to ensure proper operation. If you have repeat, consistent trips on your ground fault, the equipment should be disconnected and removed from the water. The power cord should be inspected for damage and you should call a Kasco Marine distributor or representative for further instructions.

If the supply cord becomes damaged, it must be replaced by an authorized service center, or similarly qualified persons in order to avoid a hazard.

**OBSERVATION:** Operating equipment should be observed on a regular basis (daily, if possible) for any reduction or variation in performance. If a change in performance is observed, the equipment should be disconnected from power and inspected for any material that may have clogged the system or wrapped around the shaft of the motor, especially plastic bags and fishing line. Even though Kasco Aerators & Circulators are among the most clog-resistant on the market, it is impossible to protect against all items that can clog equipment and still maintain a flow of water. These materials can be very damaging to the equipment under continued operation and must be removed as soon as possible. **ALWAYS UNPLUG THE UNIT BEFORE ATTEMPTING TO REMOVE CLOGS.**

**WINTER STORAGE:** In regions where there is significant freezing in the wintertime, Aerators should be removed from the water to protect them from the expansion pressure of the ice. In many areas, Aerators will keep some amount of ice open through the winter. However, when the water is thrust into the air, it is exposed to the colder air temperatures longer and can actually make ice thicker on the pond/lake. Storage over winter is best in a location that is out of the sun and cool, but above 0°C.

**CLEANING:** Equipment should be removed from the water at least once per year (at the end of the season in cold climates) to clean the exterior of the system, especially the stainless steel motor housing (can). The motor housing is the surface that dissipates heat into the water and any algae, calcium, etc. build-up will become an insulator that blocks heat transfer. In warmer regions it is recommended that the motor is removed and cleaned at least two to three times per year depending on conditions. In most cases a power washer will be sufficient if the unit and algae are still wet.

**SEAL AND OIL REPLACEMENT:** This is a sealed motor assembly and seals will wear out over time (similar to brake pads on a car). Replacement of the seals and a change of oil after three years may add longevity to the operation of the motor, saving you the cost of more expensive repairs. In warmer climates where the equipment runs most or all of the year, it is a good idea to replace seals more regularly than you would need to in colder climates where the unit is removed from the water for several months.

**ZINC ANODE:** A Sacrificial Zinc Anode is supplied on the shaft of all Kasco Aerators & Circulators for protection of the equipment from corrosion and electrolysis. The zinc anode should be replaced if reduced to half the original size or if white in color. Corrosion from electrolysis is more commonly associated with saltwater or brackish water, but as a matter of precaution, it is important to periodically check the zinc anode in all installations (at least every two to three months).

Seal replacement and all other repair services should be performed by Kasco Marine or a Kasco trained Authorized Repair Center. Please contact your Kasco Marine, Inc. distributor or representative for your nearest Authorized Repair Center.

## Warranty Policy

Warranty Period:

Models 2400AF, 2400CF, 3400(H)AF, 3400(H)CF,, 4400(H)AF, 4400(H)CF - 2 year Warranty

Models 8400AF, 8400CF, 2.3(H)AF, 3.1AF, 3.3(H)AF, 5.1AF, 5.3(H)AF - 3 year Warranty

Kasco® Marine, Inc. warrants this Pond Aerator or Water Circulator to be free from defects in material or workmanship (except for the ropes, power cord, and propeller) under normal use and service. The Kasco Marine, Inc. obligation under this warranty is limited to replacing or repairing free of charge any defective part within the warranty period. Customer shall pay shipping charges for returning the unit to Kasco or an Authorized Repair Center.

**THIS WARRANTY IS IN LIEU OF ANY OTHER WARRANTIES, EXPRESSED OR IMPLIED, AND ANY OTHER OBLIGATION OR LIABILITY WHATEVER ON THE PART OF KASCO MARINE, INC. AND IN NO EVENT SHALL KASCO MARINE, INC. BE LIABLE FOR ANY SPECIAL OR CONSEQUENTIAL DAMAGES.**

Warranty is void if:

- The Aerator is not maintained properly according to the Maintenance Recommendations supplied in this Own-

ers Manual.

- The Aerator is returned for repair without the power cord or if the unit, control box, or power cord are altered in any way from original shipment. Cuts in the power cord are not covered under warranty.
- The Aerator is not used with the supplied GFI control box.
- The Aerator is damaged by unauthorized tampering.
- The Sacrificial Zinc Anode around the propeller shaft shows significant deterioration. (The Anode must be inspected periodically and replaced if necessary.)

#### Warranty Claim Procedure:

The best method for establishing warranty period is by the original receipt. Also, register the Aerator online at: [www.kascomarine.com](http://www.kascomarine.com) (Under the technical tab)

Once the warranty coverage has been established, the unit may be sent to any Kasco Authorized Repair Center for evaluation and repair. Please call Kasco Marine at 715-262-4488 prior to shipping to receive any updated information and/or Repair Form, then ship to:

Kasco Marine, Inc.  
800 Deere Rd.  
Prescott, WI 54021  
Attn: Repairs

Or call Kasco Marine at 715-262-4488 to locate your nearest Authorized Repair Center. You can also email Kasco at [sales@kascomarine.com](mailto:sales@kascomarine.com).

Note: Only complete motor assemblies will be accepted for warranty repair. The power cord and all other components must be returned with the motor as originally assembled. Any missing parts will be replaced at the customer's expense and, if determined to have caused the failure, could void the entire warranty. Some parts are essential for structural support during shipping and others, such as the power cord, are essential to properly diagnose potential causes of failure. It is not necessary to return the control box, float, or nozzles with the motor assembly, unless specifically asked to by a Kasco representative.

Please include the Repair Form received from Kasco Marine or your local distributor with the shipment. If no Repair Form is available, include your name and physical address for return delivery of the repaired unit and a daytime phone number and/or e-mail address for correspondence regarding the warranty claim.

Any expedited shipping method for the return of the unit is at the customer's expense. Kasco Marine will return units repaired under warranty at our expense via ground freight

within the continental United States.

#### Other Repairs:

Most failed equipment can be repaired at substantially lower costs than replacement with new. Please ship according to the instructions in the previous section. Again, it is best to call ahead for updated information and/or Repair Form.

Kasco Marine does estimates on repairs at the request of the customer. The request for estimate should be included in the letter that accompanies the returned unit and must include a daytime phone number and/or e-mail address. Estimate options are as follows:

We will contact the customer with a total after the unit has been evaluated, but before the work is performed. We will repair the unit only if repair costs are under a stated dollar amount. Example: "Please repair if total is under \$150.00 before shipping charges."

All estimates that are rejected for repair will be destroyed unless otherwise directed by the customer. If the customer would like the unit returned, the unit will be restored as closely as possible to the condition in which it was received and shipped at the customer's expense for shipping and handling charges.

#### Billing:

All non-warranty repairs will be returned to the customer and billed C.O.D. unless otherwise directed. Kasco Marine also accepts Visa and MasterCard credit card payments. Kasco Marine will call for credit card information upon completion of the repair at the customer's request.

All other warranty and repair inquiries should be directed to Kasco Marine, Inc. at 715-262-4488 or [returns@kascomarine.com](mailto:returns@kascomarine.com)

## Troubleshooting Tips

Below are some helpful troubleshooting tips. If a problem occurs, please double check the assembly and installation instructions as well as the instructions for the proper control panel. More troubleshooting tips can be found at [www.kascomarine.com](http://www.kascomarine.com)

*"My Aerator trips the ground fault interrupter in the C-85 or C-95."*

This is the most common symptom of several possible problems. To correctly diagnose the problem, you will need to collect more information. A Ground Fault Interrupter (GFI) breaker that trips can indicate an electrical service problem, water contamination in the unit and/or cord, bad breaker, control box problems, motor problems, etc. Try to find out the answers to these questions before

you contact Kasco to narrow down the problem.

- How long does it take to trip the breaker?
- Does it always take the same amount of time to trip?
- How many times has it tripped?
- Has there been any electrical problems in the area recently?

*“My Aerator seems to run slowly.”*

This can also be a symptom of several possible problems. There could be an electrical problem where the unit is not getting the proper voltage. This could also indicate a problem with the motor of the unit, which needs to be looked at by an Authorized Repair Center. Check that the unit is receiving the proper voltage, and, if so, contact Kasco for further steps.

*“My Aerator hums, but will not start. When I spin the prop with a stick, it starts up.” (for single phase units only)*

This indicated a problem with the Starting Capacitor. Each Kasco Aerator is equipped with a Starting Capacitor to get the unit going when it is first plugged in. If it is operating, but not spinning and can be started by spinning the prop with a stick, the Starting capacitor needs to be replaced by an Authorized Repair Center.

*“My Aerator turns itself off and back on without the timer and without tripping the GFI breaker.” (for single phase units only)*

Each Kasco unit has a Thermal Overload built in that will turn the unit off when it overheats. Once the unit has cooled down, it will start back up. If you are noticing these symptoms, the unit should be unplugged immediately because the Thermal Overload will continue to turn on and off until it burns out and damages the motor. The unit should be unplugged and taken out of the water to find the cause of the problem. The problem could be one of many, such as, low water levels, build-up on the unit to prevent heat dissipation, something inhibiting the free rotation of the shaft, etc. If something is caught in the unit or there is a build-up on the unit, remove the debris and, if caught early enough, the unit should be fine. Contact a Kasco representative before restarting the unit.

*“My Aerator flow seems to fluctuate and/or be less than usual.”*

This can occur because of a few different reasons. Most of the time, this symptom is caused from unit being clogged with debris. A mat of weeds, many leaves, plastic bags, etc. can clog up the unit and cause it to be starved of water. If the unit does not have the proper amount of water, the flow or pattern will fluctuate up and down and look sporadic. If you are seeing these symptoms, unplug the unit and clean away the debris that is clogging up the screen. Another possibility if these symptoms are noticed, is a

chipped or damaged prop that is causing the unit to wobble and not pump properly. When the unit is unplugged, check the prop for damages and replace if damage is found.

*“The GFI breaker trips randomly and sporadically. Sometimes it is a few hours of operation, other times it can be days or weeks.”*

This is referred to as a Nuisance Trip. This usually occurs where the unit is installed a great distance from the initial electric service on the property where the ground stake is placed. It is caused by either induced current in the ground wire or a base voltage difference due to soil pH levels. A possible resolution to the problem, contact an electrician and install a local grounding stake. This may eliminate the induced current and any base voltage differences.



800 Deere Rd.  
 Prescott, WI 54021  
 Phone: 715-262-4488 - Fax: 715-262-4487  
 www.KascoMarine.com Sales@KascoMarine.com

### Customer Repair Form

**\* Important Reminders \***

- All repairs sent in **MUST** be accompanied by a copy of this completed sheet!
- Routine maintenance consists of checking the zinc anode regularly and replacing if necessary, keeping the unit clean, keeping the stainless steel can clean, and having the seals and oil replaced every 3 years depending on use.
- Address your Repair to Kasco Marine, Attn: Repairs (or to your Authorized Repair Center).
- Shipping to Kasco or an Authorized Repair Center is paid for by the customer.
- You must include the power cord and cage assembly/fountain housing with each unit sent in for repair to be considered for warranty and for proper repair and shipping protection!
- Do not ship the float and/or control box with the unit for repair, unless otherwise instructed.

Today's Date: \_\_\_\_\_

**Customer Information**

Name: \_\_\_\_\_

Phone Number: \_\_\_\_\_

Address: \_\_\_\_\_

Alternate Number: \_\_\_\_\_

City: \_\_\_\_\_

Email Address: \_\_\_\_\_

State: \_\_\_\_\_

Zip Code: \_\_\_\_\_

**Unit Information:**

Model # (Ex. 3400AF): \_\_\_\_\_

Serial # (Ex. 7001A34025): \_\_\_\_\_

Date Purchased: \_\_\_\_\_

Purchased From: \_\_\_\_\_

Earliest Date of Problem: \_\_\_\_\_

Description of Problem:

Comments:



## Registration Information

Please register your aerator online at:

[www.kascomarine.com](http://www.kascomarine.com)

Also fill in the information below and keep for your records.

Model # (Ex. 3.1AF) \_\_\_\_\_

Serial # (Ex. 8001A311725) \_\_\_\_\_

Purchase Date: \_\_\_\_\_

Purchased From: \_\_\_\_\_

Registration Date: \_\_\_\_\_



Kasco Marine, Inc.  
800 Deere Rd.  
Prescott, WI 54021

Phone (715) 262-4488 \* Fax (715) 262-4487

[www.kascomarine.com](http://www.kascomarine.com) \* [sales@kascomarine.com](mailto:sales@kascomarine.com)